



Quality Management
ISO 9001:2008
▶ Voluntary participation
in regular monitoring



SYSTEMS AUTOMATION & MANAGEMENT PTY LTD.

HYBRID-WORX®

For an optimised system solution, high fuel saving potential and real industry know-how, use Hybrid-Worx®.



Over 25 Years of Service Excellence in the Technology Industry.

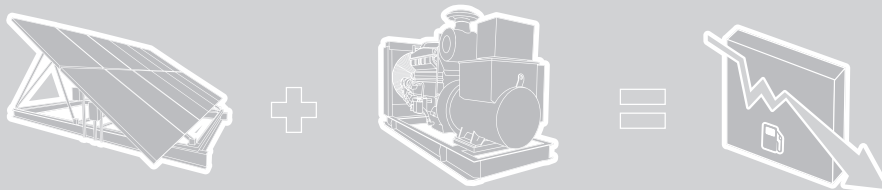

www.sam.co.za

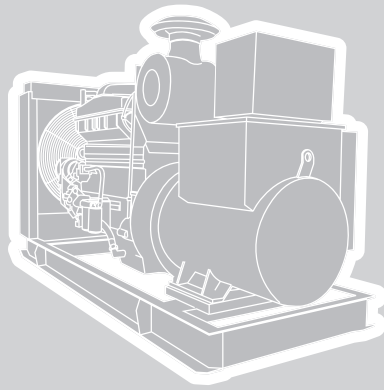
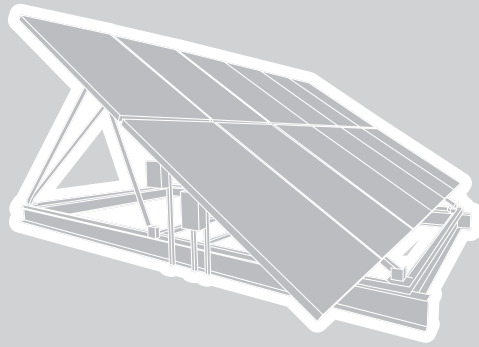



SYSTEMS AUTOMATION & MANAGEMENT PTY LTD.

INDEX

Why SAM's Hybrid-Worx®?	1
Hybrid-Worx® applications cover a wide range of industries	2
Reduction of fuel consumption by Hybrid-Worx® Systems	3
Hybrid-Worx® is already a real business solution in high irradiation regions	4
SAM's Hybrid-Worx® solution provides an easy add-on approach to existing plants	5
SAM's Hybrid-Worx® Controller enables intelligent communication	6
SAM's solution allows for a scalable deployment of PV's	7
Each Genset plant and load profile are different, optimal PV ratio is key	8
SAM provides tools for optimal system design	9
Contact Details	10

Over 25 Years of Service Excellence in the Technology Industry.

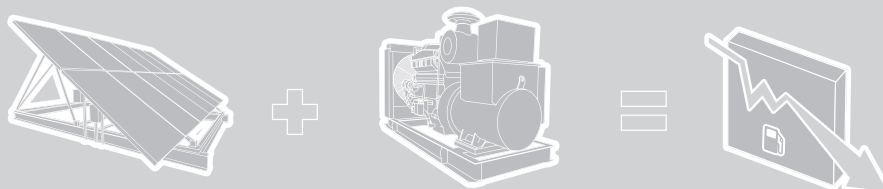

www.sam.co.za



SYSTEMS AUTOMATION & MANAGEMENT PTY LTD.

WHY SAM's HYBRID-WORX[®]?

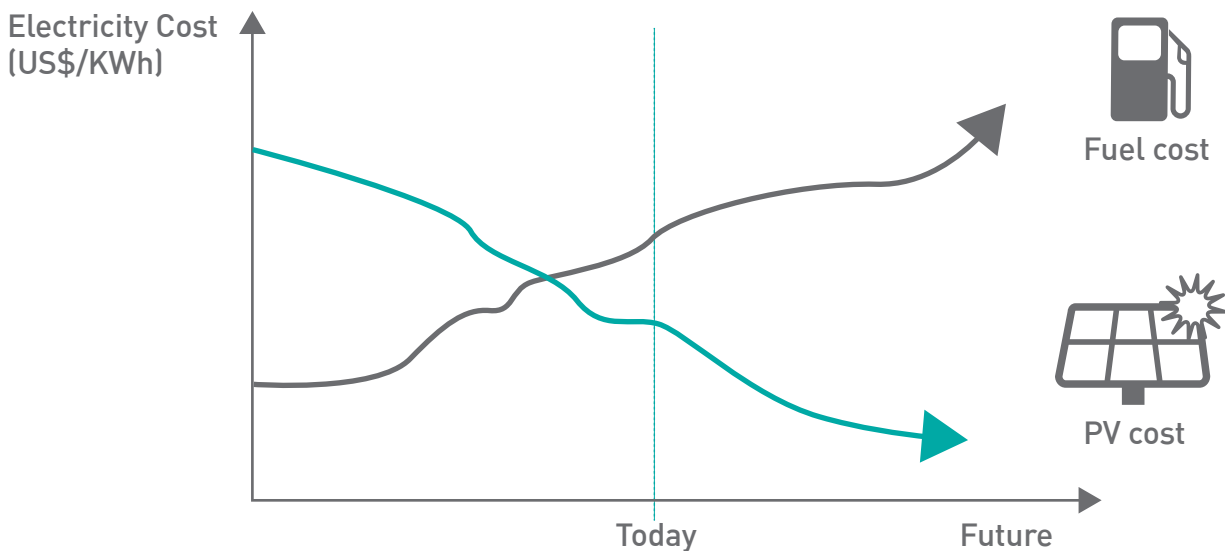

- PV costs decreased by 50% in the last few years
- Fuel cost for Gensets are steadily rising
- Hybrid-Worx[®] applications provide energy saving opportunities for Genset operators/End users

Today, we see the significant cost advantage of changing to Hybrid-Worx[®] compared to conventional Diesel Gensets. This cost gap will become ever increasing in the future.









SYSTEMS AUTOMATION & MANAGEMENT PTY LTD.

HYBRID-WORX® APPLICATIONS COVER A WIDE RANGE OF INDUSTRIES

CRITERIA FOR A FAVOURABLE INDUSTRIAL HYBRID-WORX® SYSTEM

- Significant amount of 24/7 base load Gensets
- Fit of load curve and daily profile of PV power
- Sufficient space available for PV installation
- Application size for PV: > 0.5 MW
- Effective Diesel fuel cost³ > 1 US\$/litre for Genset operator
- End user mindset: need to save OpEx¹, CO₂ obligations, and /or will to 'go green'

HYBRID-WORX® SYSTEM USES

-  **Utilities / IPP²**
(in off-grid / weak-grid regions)
-  **Remote Industries**
(e.g. mining, oil & gas, desalination)
-  **Agriculture**
(e.g. irrigation systems)
-  **Tourism**
(e.g. hotels, resorts)
-  **Real Estate**
(e.g. offices, warehouses)

What benefit brings a Hybrid-Worx® System compared to standard Gensets?

1. Operational Expenditures 2. Independent Power Producer
 3. Effective cost at point of consumption including fuel transportation and storage cost etc.

Over 25 Years of Service Excellence in the Technology Industry.

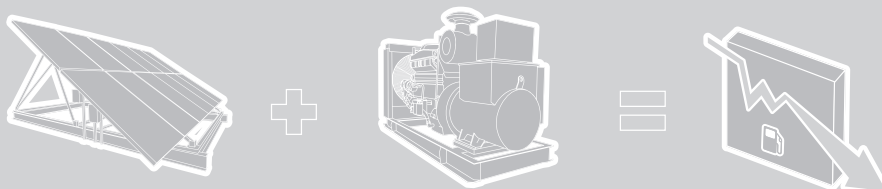



SYSTEMS AUTOMATION & MANAGEMENT PTY LTD.

REDUCTION OF FUEL CONSUMPTION BY HYBRID-WORX® LEAD TO SIGNIFICANT SAVINGS

ASSUMPTIONS (BASE SOLUTION)

- System is designed such that all generated PV energy can be used
- No annual increase of fuel cost included
- PV plant size: 2 MWp
- Solar irradiation: 160 kWh//kWpp.a.
- PV system cost¹: 2000 US\$/kWp CapEx (+ OpEx 2% p.a.)
- Effective Diesel fuel cost: 1.30 US\$/litre
- Genset efficiency: 3.5 kWh/litre
- PV financing: 30% equity, 70% debt (with 7% interest rate and 5 year amortization time); cash flow discount factor: 8%

DCF² ANALYSIS

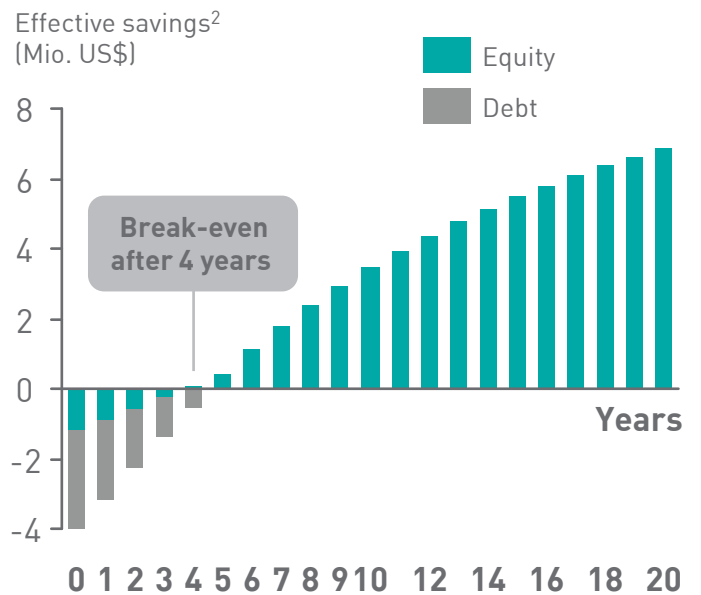

• Payback time of the investment for the Hybrid-Worx® is just 4 years

• After 10 years, effective (net) savings are nearly 4 Mio. US\$.

1. PV system cost is significantly dependant on country and project specifications
 2. Discounted cash flows





SYSTEMS AUTOMATION & MANAGEMENT PTY LTD.

HYBRID-WORX® IS ALREADY A REAL BUSINESS SOLUTION IN HIGH IRRADIATION REGIONS

with effective Diesel cost less than a 1 US\$/Litre.

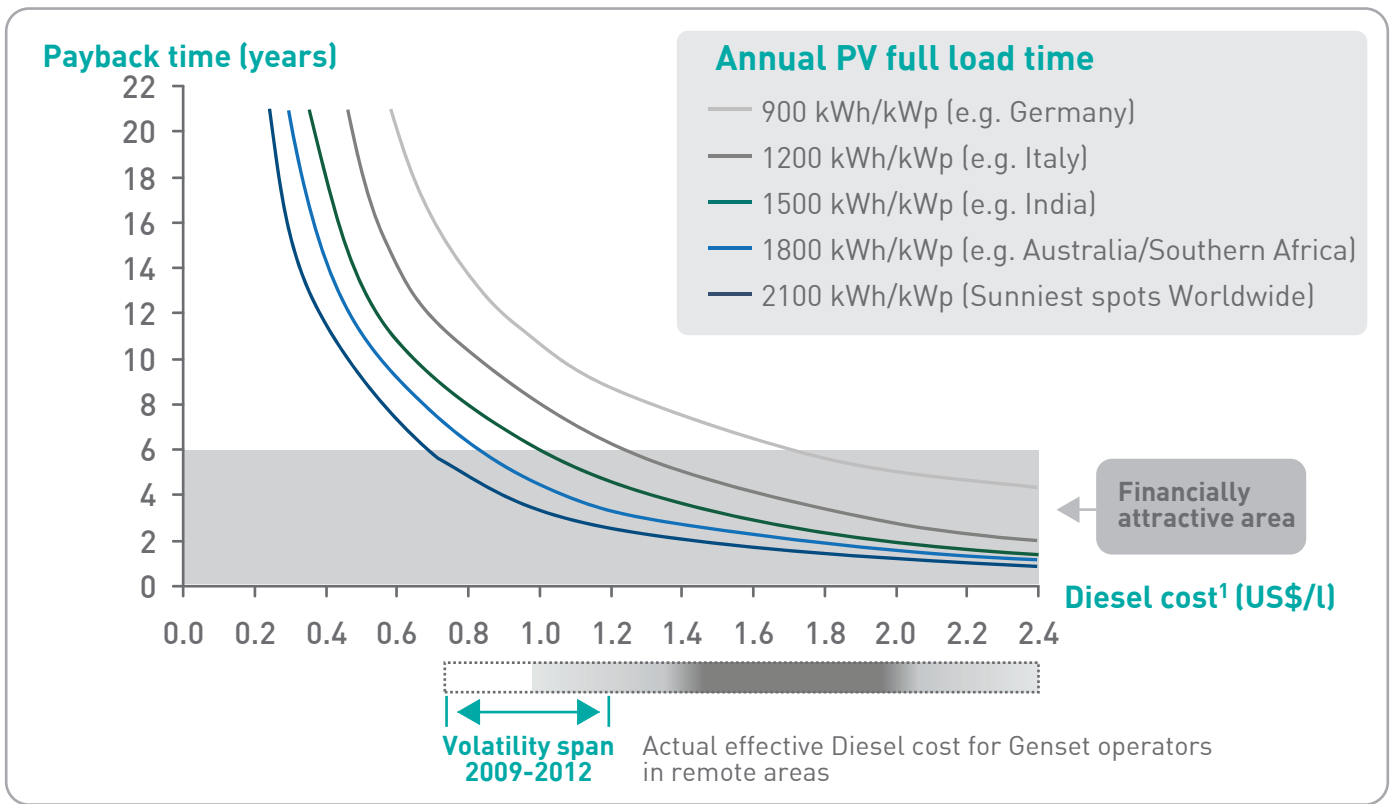

Given the Diesel price volatility and Genset industry mindset, a short payback time is crucial.

1. Effective cost at point of consumption including fuel transportation and storage cost etc.
Assumptions: 1 MW PV plant; 100% consumption of PV power possible; Cap Ex=2,000 US\$/kWp; OpEx= 2% of CapExp.a.; PV financing with 30% equity/70% debt with 7% interest rate and amortisation time of 5 years; Genset efficiency 3.5 kWh/l (net electricity production); CapEx and Maintenance cost for Diesel Genset not included, since PV is considered as add-on here, not as Genset hardware substitution.

Over 25 Years of Service Excellence in the Technology Industry.

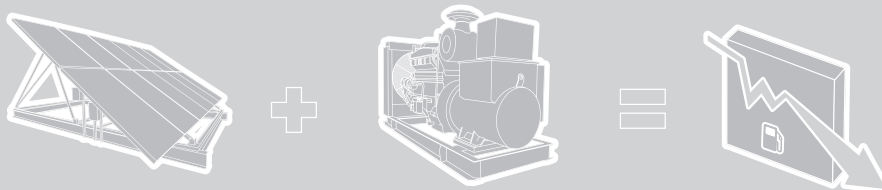



SYSTEMS AUTOMATION & MANAGEMENT PTY LTD.

SAM's HYBRID-WORX® SOLUTION PROVIDES AN EASY ADD-ON APPROACH TO EXISTING PLANTS

as well as Greenfield projects.

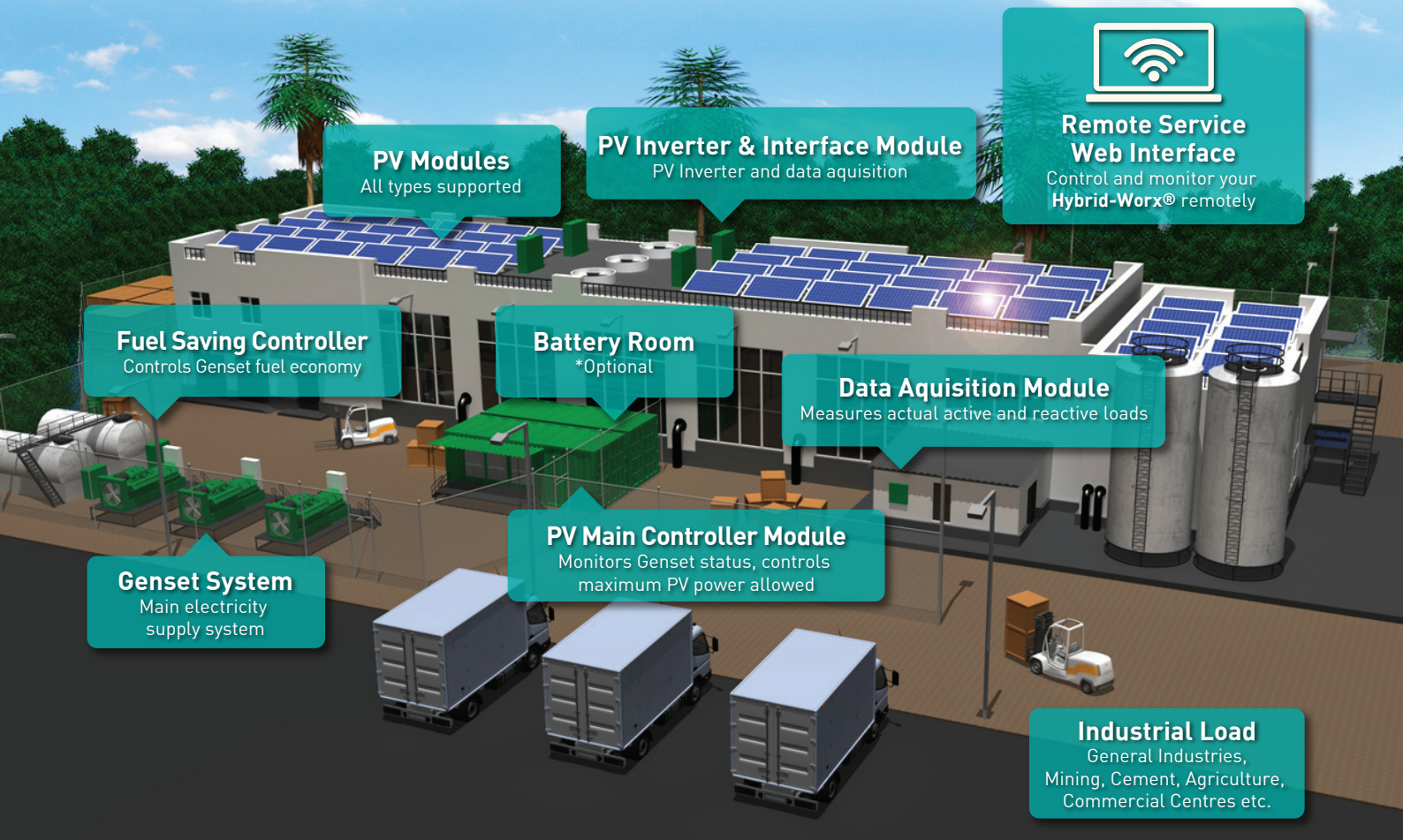

Today, we see the significant cost advantage of changing to Hybrid-Worx® compared to conventional Diesel Gensets. This cost gap will become ever increasing in the future.





SYSTEMS AUTOMATION & MANAGEMENT PTY LTD.

SAM's HYBRID-WORX[®] CONTROLLER ENABLES INTELLIGENT COMMUNICATION

between PV's, Gensets and Load.

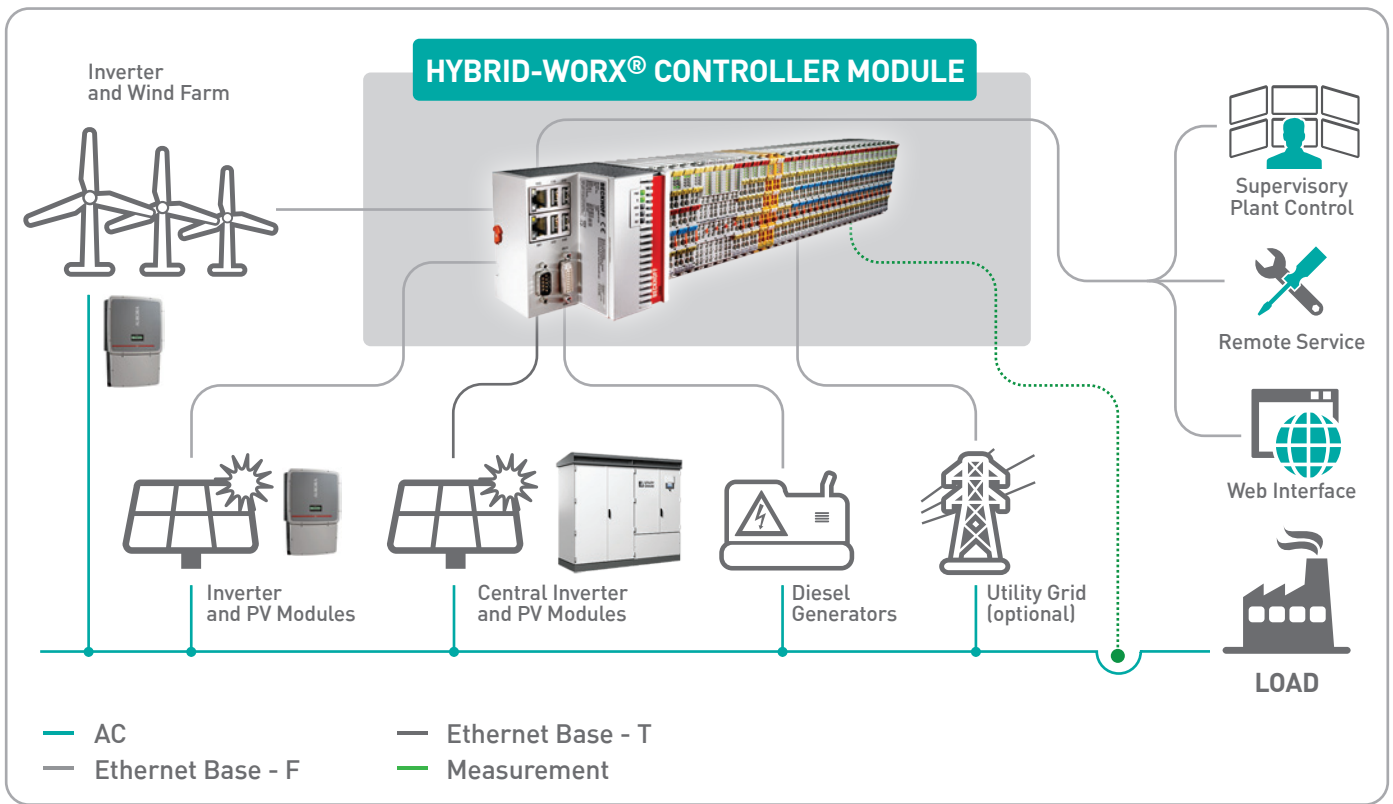

With the Hybrid-Worx[®] Controller and Inverters, we can achieve PV penetration levels¹ up to 60% while still securing overall system stability and smooth Genset control².

1. Ratio between nominal PV power and nominal Genset power (of Gensets running at the simultaneously)
2. Accounting e.g. for minimum Genset load and spinning reserve

Over 25 Years of Service Excellence in the Technology Industry.

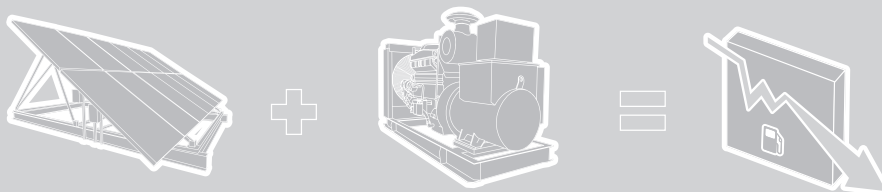



SYSTEMS AUTOMATION & MANAGEMENT PTY LTD.

SAM's HYBRID-WORX® SOLUTION ALLOWS FOR SCALABLE DEPLOYMENT OF PV's

PV INVERTERS



- Robust design proven in harsh environments
- High tolerance for wide voltage and frequency ranges
- Integrated management functions for weak grid
- Up to 20% PV penetration¹ possible

BATTERY INVERTERS

SPINNING REVERSE

- Storage integration to substitute spinning reserve/idle Genset operation²

GRID MANAGER

- Increased PV penetration of 100-120% to reach economic optimum, including support for diesel off-mode

HYBRID-WORX® CONTROLLER



- Intelligent and fast interfacing between load, Genset and PV inverter
- Several operation modes for maximum compatibility
- Integrated management functions for weak grid
- With inverters: up to 60% PV penetration¹ possible

ENABLING SERVICES

- Energy Audit
- Remote Monitoring
- Design-Hybrid Edition
- System/grid stability analysis

1. Ratio between PV peak power and Genset nominal power
2. Approximately, ca. 5% additional savings of fuel cost possible





SYSTEMS AUTOMATION & MANAGEMENT PTY LTD.

GENSET PLANTS AND LOAD PROFILES DIFFER, DEFINING OPTIMAL PV RATIOS IS KEY

for maximising custom business solutions.

INCREASING THE PV PENETRATION IS KEY ...

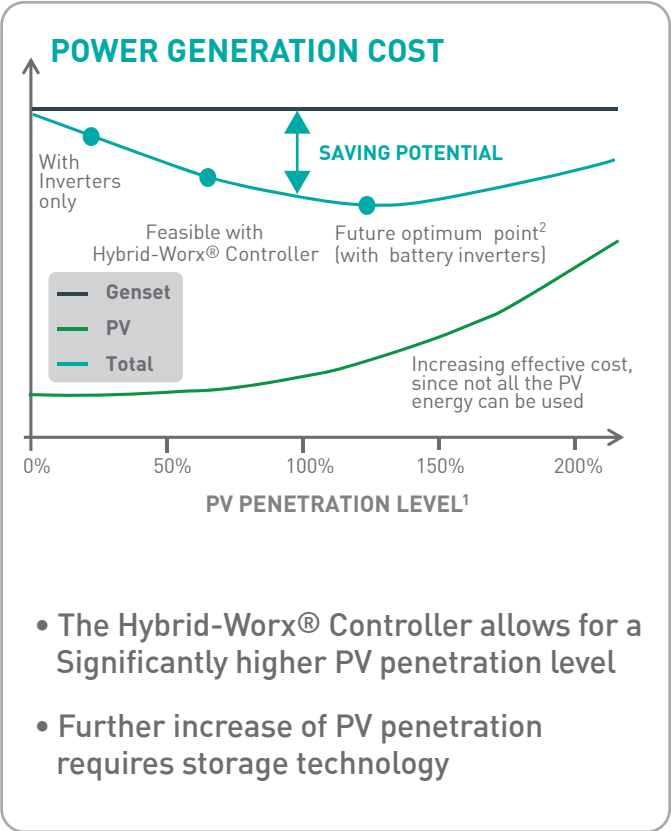

... HOWEVER, LOAD PROFILE DETERMINES PV USABILITY

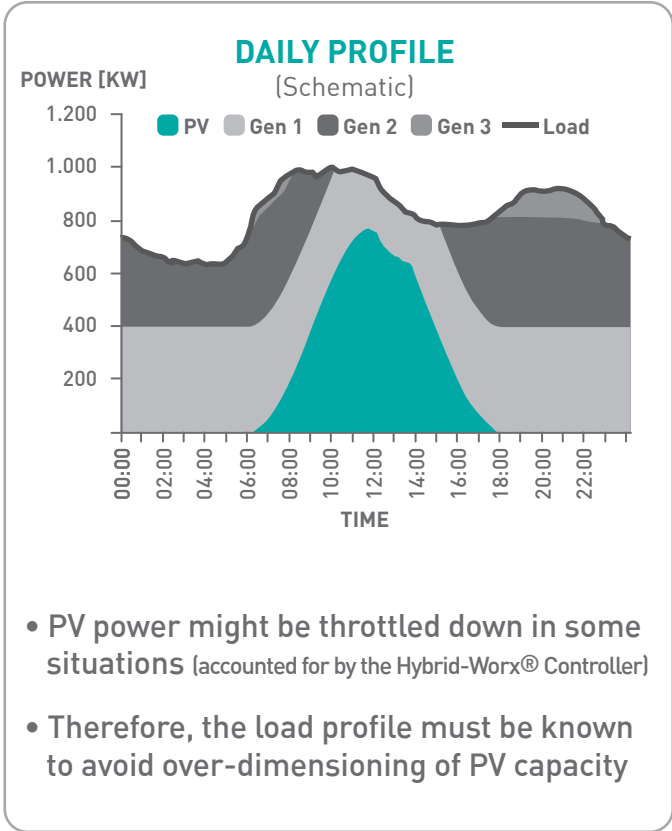

1. Ratio between PV peak power and Genset nominal power capacity (of Gensets running at the same time)
 2. Once advanced storage technology is in place

Over 25 Years of Service Excellence in the Technology Industry.

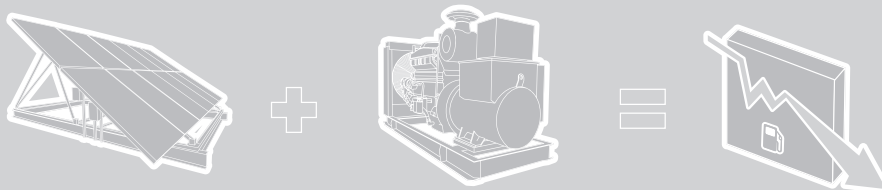



SYSTEMS AUTOMATION & MANAGEMENT PTY LTD.

SAM PROVIDES TOOLS FOR OPTIMAL SYSTEM DESIGN

and translates this directly into financial benefits for the end customer.

OPTIMAL SYSTEM DESIGN

- Specific solar irradiation, Genset power and load profile are considered to determine the optimal PV system
- Genset specifications (minimum load, spinning reserve etc.) are also taken into account
- Detailed system /grid stability analysis is offered as additional service

SIMULATION OF FINANCIAL BENEFIT

- Payback time for PV investment is analysed as a function of the fuel price
- For a fixed fuel price, the overall saving potential for the hybrid plant owner is analysed based on a DCF¹ simulation

Payback Time for PV-System

(pure fuel save approach)

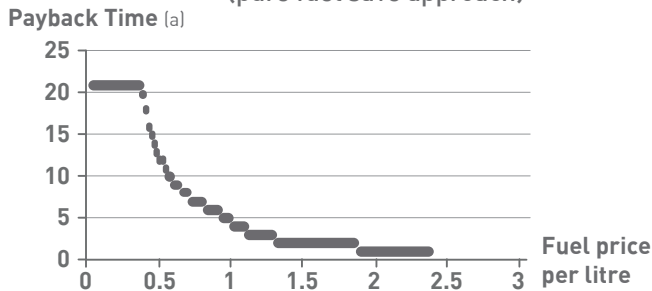

Effective Savings

Cumulative discounted as follows:

Savings ('000 US\$)

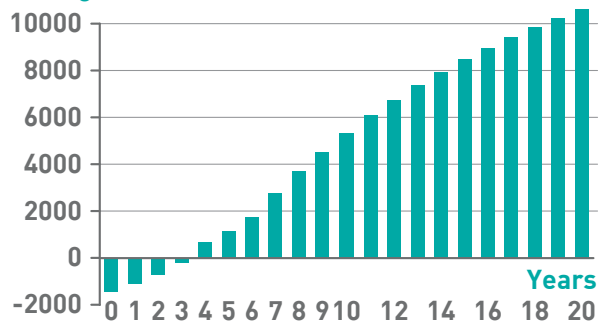

With quick, transparent and reliable information on technical and financial feasibility, we support our customers to find the best solution!

1. DCF = discounted cash flow





SYSTEMS AUTOMATION & MANAGEMENT PTY LTD.

HEAD OFFICE | GAUTENG

13 -17 Rembrandt Str.
Petervale | Bryanston

P O Box 97757
Petervale | 2151 | Z.A.

Tel. +27 (0)11 803 0570
+27 (0)11 231 8900
Fax. +27 (0)11 803 3486

Email. info@sam.co.za

BRANCH | GAUTENG

1 Hartshorne Str.
Rynfield | Benoni

P O Box 97757
Petervale | 2151 | Z.A.

Tel. +27 (0)11 803 0570
+27 (0)11 231 8900
Fax. +27 (0)11 803 3486

Email. info@sam.co.za

BRANCH | KWAZULU NATAL

1 Hawthorne Park | 1 Hawthorne Rd.
Mahogany Ridge | Pinetown

P O Box 163
Kloof | 3640 | Z.A.

Tel. +27 (0)31 700 6171
Fax. +27 (0)31 700 6172

Email. info@samkzn.co.za

POINTS OF PRESENCE

Lephalale | Northern Province
Tel. +27 (0)82 574 6909

Pietermaritzburg | Kwazulu Natal
Tel. +27 (0)82 921 5663

Richards Bay | Kwazulu Natal
Tel. +27 (0)83 950 8070

Saldanha | West Coast
Tel. +27 (0)82 712 9555



For a optimised system solution, high fuel saving potential and real industry know-how, use SAM's HYBRID-WORX[®] SYSTEM.

Over 25 Years of Service Excellence in the Technology Industry.

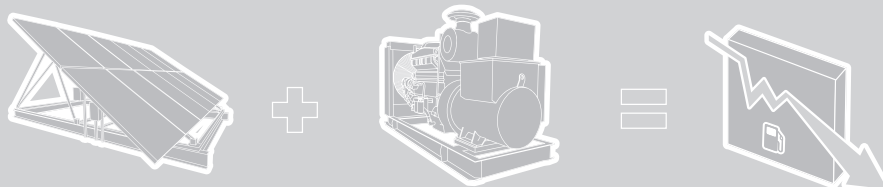

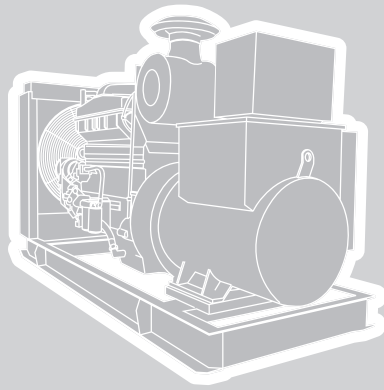
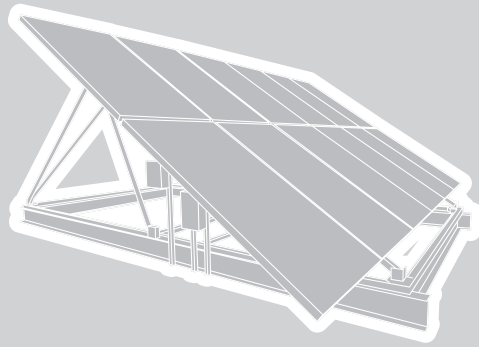

www.sam.co.za

